

QUIET RUNNING

HORIZONTAL MULTI-STAGE CENTRIFUGAL PUMPS

Applications:

To work with clean water in domestic applications, irrigation, and hydropneumatic sets.



SINGLE PHASE

HMP45/45P

Quiet running horizontal multi-stage centrifugal pumps.

Materials:

Pump body and impellers in stainless steel AISI-304.

Motor shaft in stainless steel AISI-420.

Diffusers in PPOGF30.

Suction and discharge mountings in cast iron.

Mechanical seal in graphite and steatite / upon request.

Motor housing in aluminium L-2521.

HMP-P self-priming up to 2m. For domestic and industrial supplies, irrigation and hydropneumatic sets.

HMP built-in self-priming valve, not very sensitive to impurities. Self-priming up to 9m. To work with clean water in domestic and industrial application, irrigation, and pressure sets.

Motor:

Asynchronous, two poles.

IP 55 protection.

Class F insulation.

Continuous operation.

Single phase version built-in thermal protector upon request.

TECHNICAL DATA

Model	KW	V		A		P1(KW)		Q	H(m)	Flow Rate					
		1~	3~	1~	3~	1~	3~			L/min	0	57	95	114	200
		50HZ	50HZ	220	380	1~	3~			m³/h	0	3.4	5.7	6.8	12
HMP45/45P-2M	1.1	220	380	6.3	2.6	1.4	1.3		28	26	23	20	10		
HMP45/45P-3M	1.5	220	380	8.0	3	1.8	1.7		39	35	33	30	17		
HMP45/45P-4M	1.8	220	380	10.1	4	2.3	2.2		48	45	42	39	23		
HMP45/45P-5M	2.2	220	380	13.1	4.8	2.7	2.7		61	56	53	49	30		

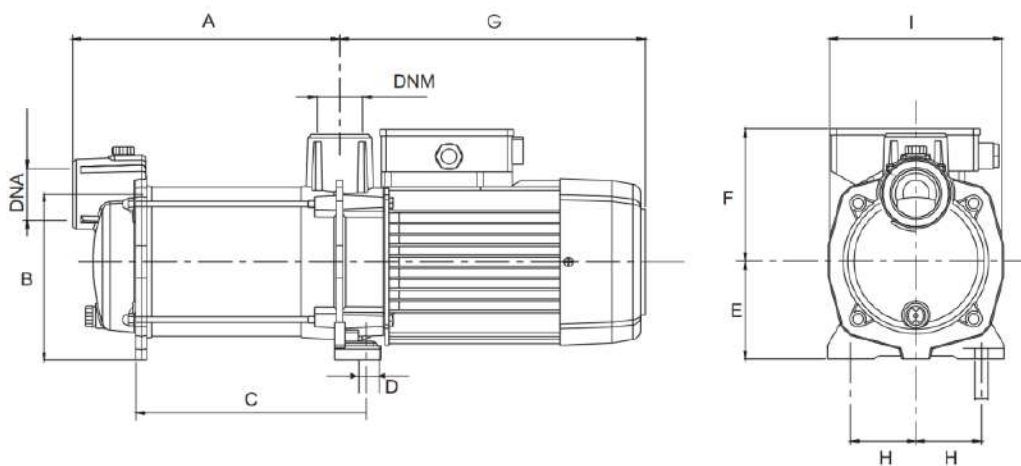
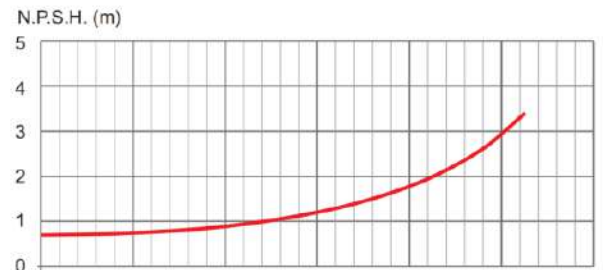
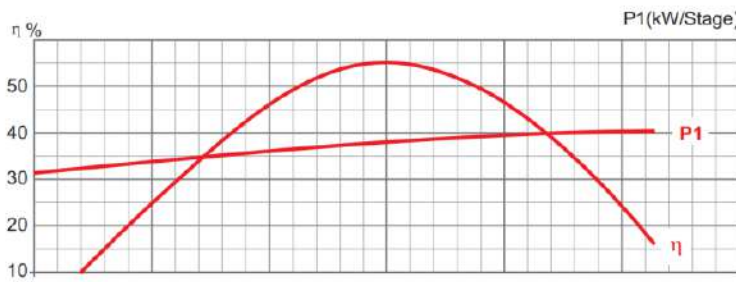
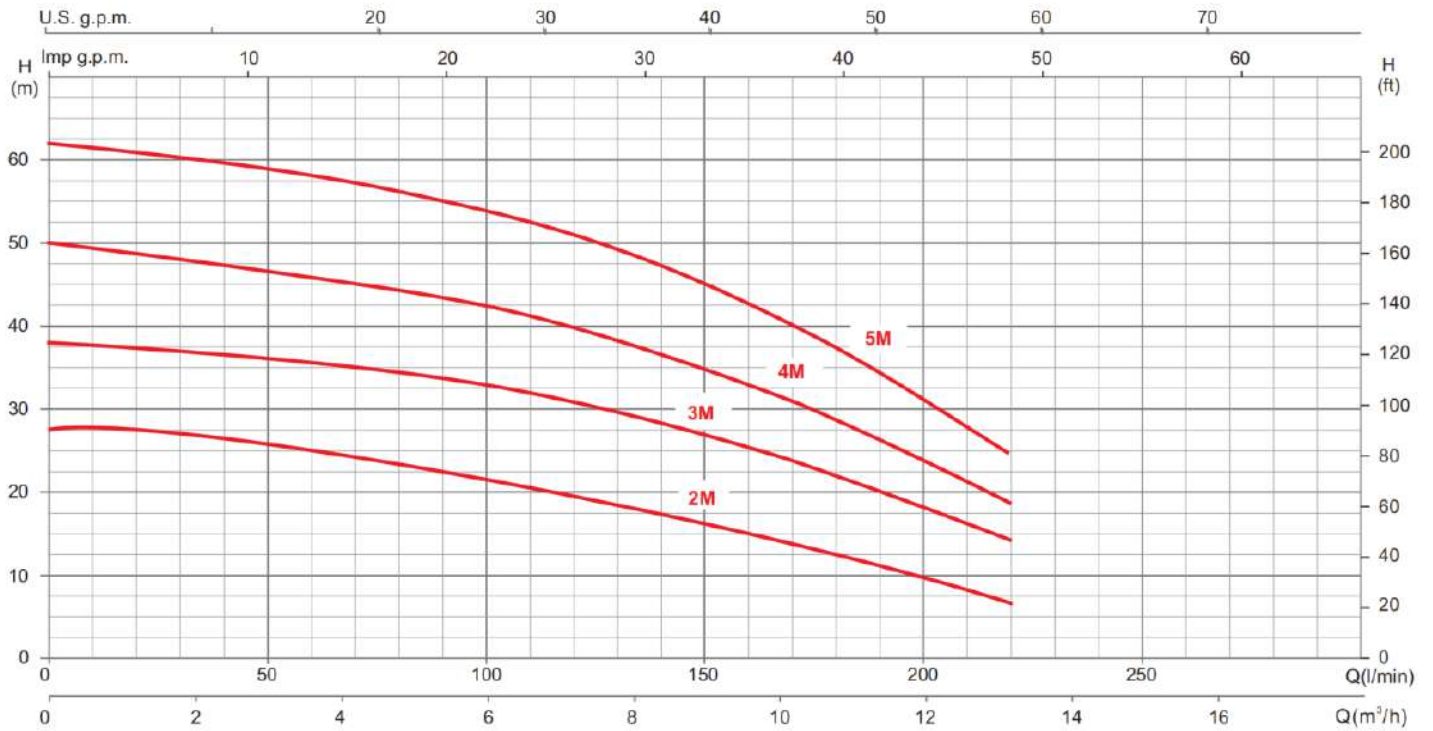

DIMENSIONS

Model	A	B	C	D	E	F	G	H	I	DNA	DNM	Kg
HMP45/45P-2M	215.5	145	237	18	90	105	275	60	160	1½"	1¼"	19.0
HMP45/45P-3M	246	145	263.5	18	90	105	275	60	160	1½"	1¼"	20.1
HMP45/45P-4M	276	145	290	18	90	105	275	60	160	1½"	1¼"	21.4
HMP45/45P-5M	307	145	337.5	18	90	105	296	60	160	1½"	1¼"	22.6