

QUIET RUNNING

HORIZONTAL MULTI-STAGE CENTRIFUGAL PUMPS

Applications:
To work with clean water in domestic applications, irrigation, and hydropneumatic sets.



THREE PHASES



HMP25/25P

Quiet running horizontal multi-stage centrifugal pumps.

Materials:

Pump body and impellers in stainless steel AISI-304.

Motor shaft in stainless steel AISI-420.

Diffusers in PPOGF30.

Suction and discharge mountings in cast iron.

Mechanical seal in graphite and steatite / upon request.

Motor housing in aluminium L-2521.

HMP-P self-priming up to 2m. For domestic and industrial supplies, irrigation and hydropneumatic sets.

HMP built-in self-priming valve, not very sensitive to impurities. Self-priming up to 9m. To work with clean water in domestic and industrial application, irrigation, and pressure sets.

Motor:

Asynchronous, two poles.

IP 55 protection.

Class F insulation.

Continuous operation.

Single phase version built-in thermal protector upon request.

TECHNICAL DATA

Model	KW	V		A		P1(KW)		Q	L/min	0	45.8	76.7	91.7	100
		1~	3~	1~	3~	1~	3~							
		50HZ	50HZ	220	380	1~	3~							
HMP25/25P-2M	0.55	220	380	3.6	1.7	0.9	0.85	H(m)	22.5	19.5	16	14	12	
HMP25/25P-3M	0.75	220	380	5.0	2.0	1.2	1.12		31.5	29.0	24	20.5	16	
HMP25/25P-4M	0.92	220	380	6.4	2.5	1.5	1.4		43.5	39.5	34.2	30.0	24	
HMP25/25P-5M	1.1	220	380	7.4	3.0	1.8	1.7		54	49.0	41.5	37.0	30	
									m ³ /h	0	2.75	4.6	5.5	6.0

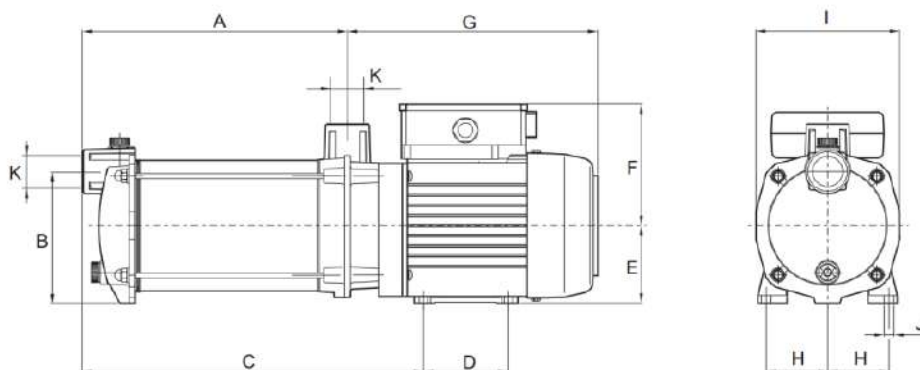
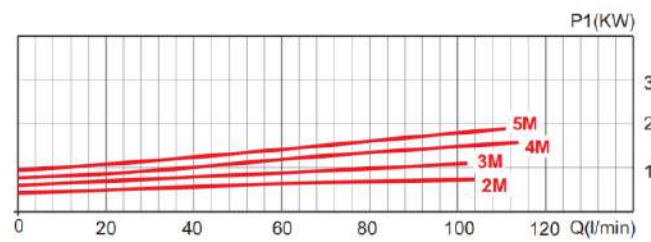
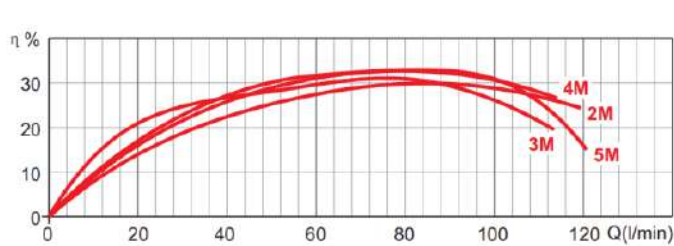
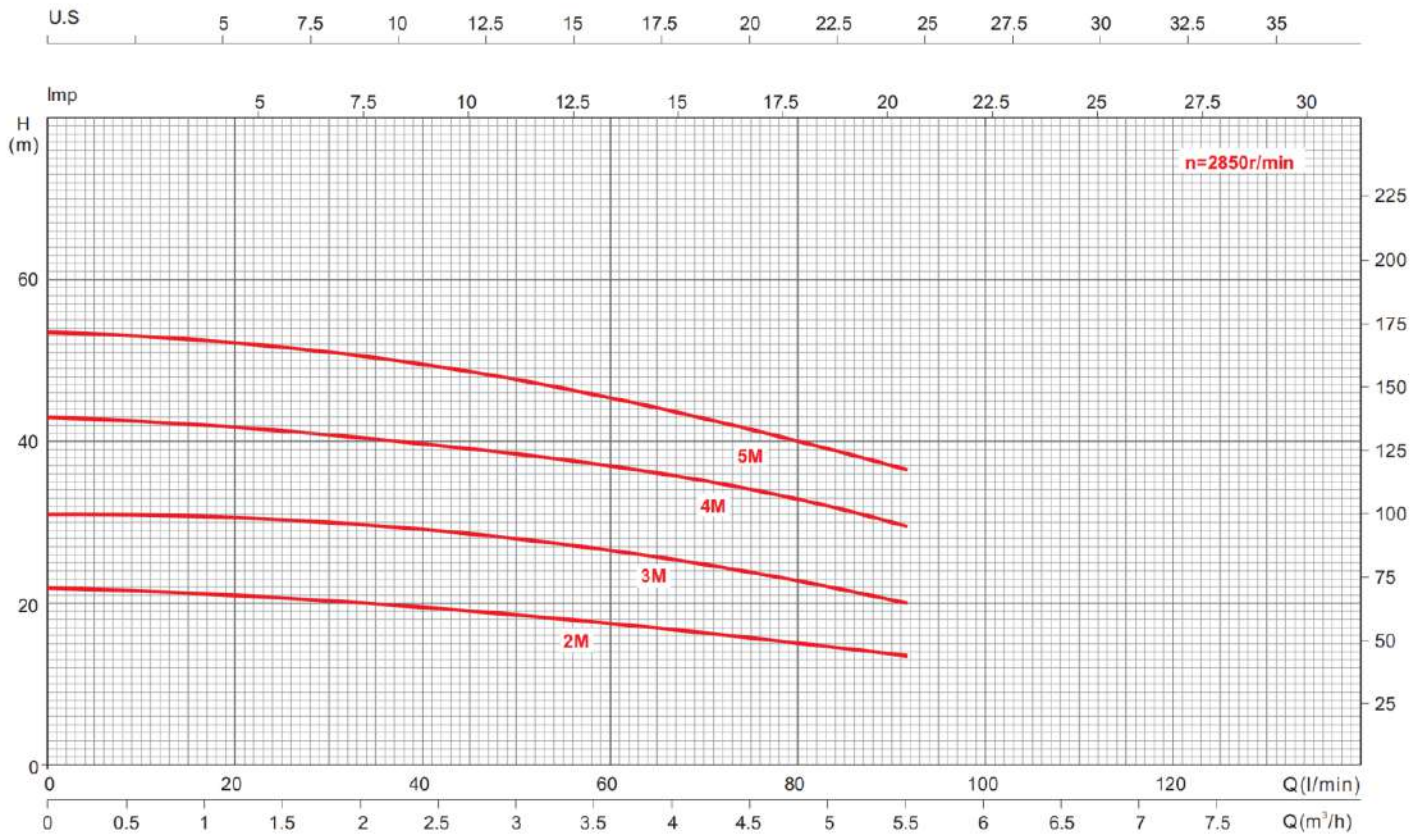

DIMENSIONS

Model	A	B	C	D	E	F	G	H	I	J	K	Kg
HMP25/25P-2M	175.5	130	226	82	71	115	230	59	140	8	1"	12
HMP25/25P-3M	202	130	252	82	71	115	230	59	140	8	1"	12.6
HMP25/25P-4M	228.5	130	279	82	71	115	230	59	140	8	1"	14
HMP25/25P-5M	252	130	328	82	71	126	251	59	140	8	1"	17